

THIS DRAWING IS UNPUBLISHED. RELEASED FOR PUBLICATION, 19 .
 © COPYRIGHT 19 BY AMP INCORPORATED. ALL INTERNATIONAL RIGHTS RESERVED.

LOC	DIST	P	F	ZONE	LTR	DESCRIPTION	DATE	APPD
G	14				C	REV & REDRAWN PER 0720-0040-93	3-24-93	APP DAP

METRIC
 DIMENSIONS LISTED IN mm [INCHES]

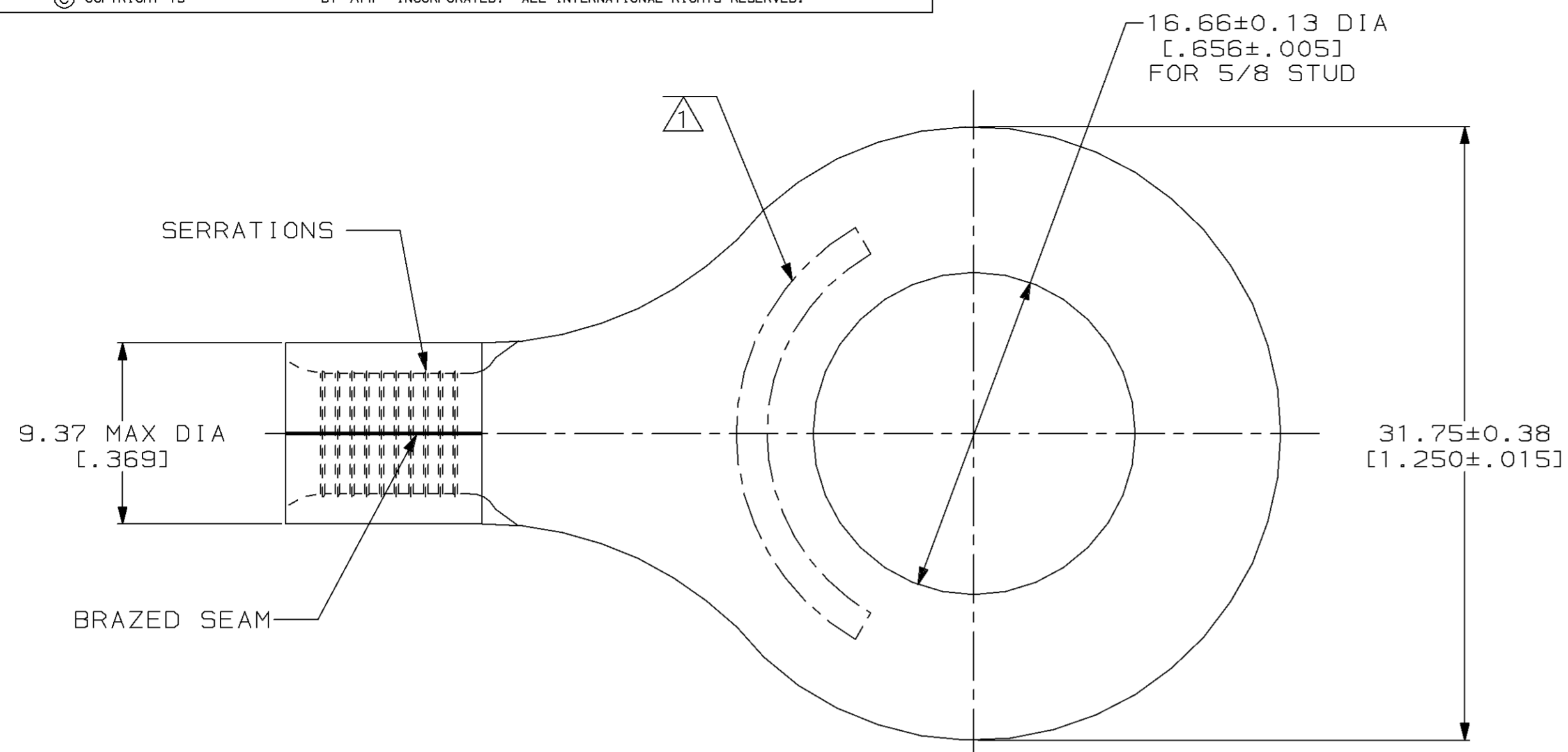

AMP WIRE RANGE	UL Listed
6 AWG SOLID OR STRANDED	6 AWG STRANDED
SR LR7189 Certified	MILITARY P/N AND CLASS
6 AWG SOLID OR STRANDED	NOT APPLICABLE

1 STAMP AMP 6* APPROX AS SHOWN

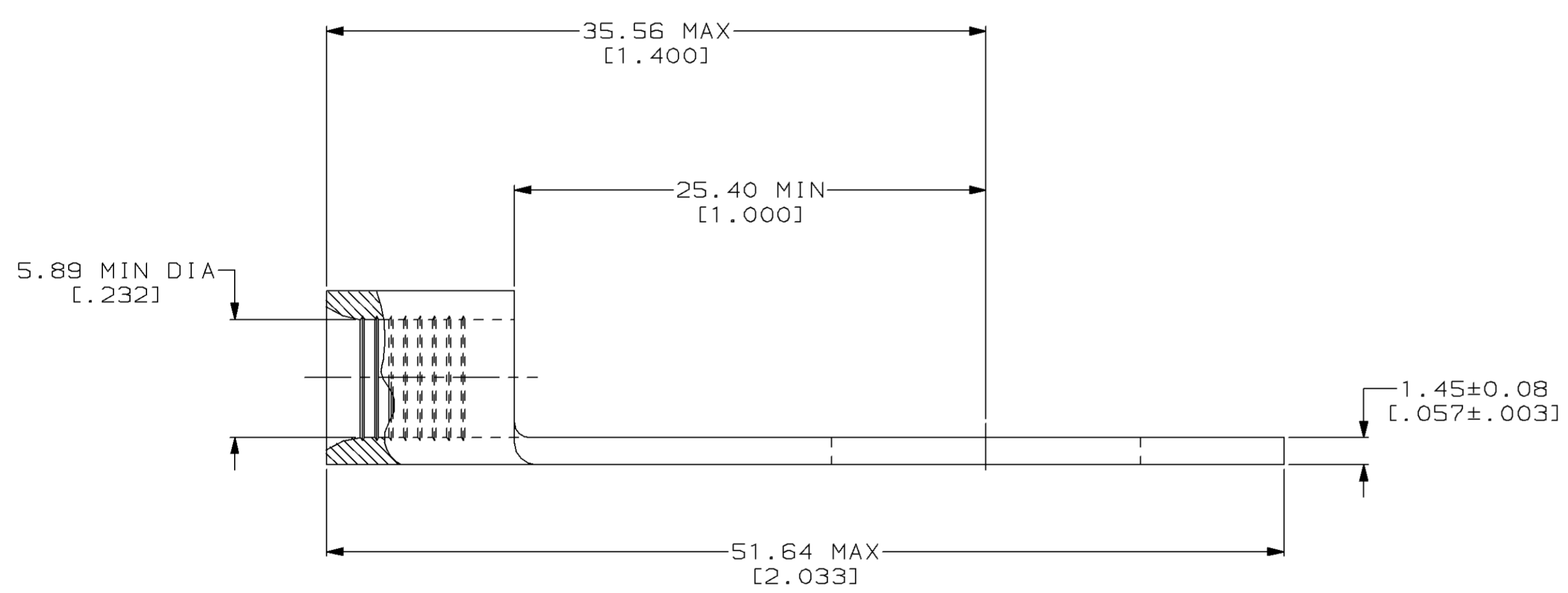

AMP INCORPORATED CUSTOMER SERVICE SYSTEMS		MAX RECOMMENDED OPERATING TEMPERATURE: 170°C MAX	DO NOT SCALE PRINT. UNLESS SPECIFIED DIMENSIONS IN mm [INCHES] TOLERANCES ON: 2 PLC DEC ± - 3 PLC DEC ± - ANGLES ± -	DR 3-24-93 TA BRINKMAN	36809 PART NO	
FOR ADDITIONAL PRODUCT INFORMATION OR COPIES OF DRAWINGS AND TECHNICAL DOCUMENTS	PRODUCT INFORMATION CENTER 1-800-522-6752	VOLTAGE RATING: NOT APPLICABLE	MATERIAL COPPER PER ASTM B-152 ANNEALED	CHK 3-24-93 DA PATTERSON	AMP AMP Incorporated Harrisburg, PA 17105-3608	
FOR APPLICATION TOOLING INFORMATION	TOOLING ASSISTANCE CENTER 1-800-722-1111	WIRE CROSS SECTIONAL AREA RANGE: 10.5-16.8MM² [20,800-33,100] CIR MILS SOLID OR STRANDED	FINISH TIN PLATE 0.00254[.000100] MIN THK PER MIL-T-10727	APPD 3-24-93 DE MILLER	NAME TERMINAL, RING TONGUE, SOLISTRAND™	
FOR ORDER ENTRY	1-800-526-5142	THIS DRAWING IS A CONTROLLED DOCUMENT FOR AMP INCORPORATED. IT IS SUBJECT TO CHANGE AND THE CONTROLLING ENGINEERING ORGANIZATION SHOULD BE CONTACTED FOR THE LATEST REVISION.		APPD 3-24-93 JL MECKLEY	SIZE CAGE CODE DRAWING NO	SCALE 4:1 C=36809
AMP 1471-6 REV 3-92				PRODUCT SPEC -	WEIGHT -	SHEET 1 OF 1

CUSTOMER DRAWING